

REVISION RECORD

| REV | ECN | DESCRIPTION | DRFT | DATE |
|-----|-----|-------------|------|------|
|-----|-----|-------------|------|------|

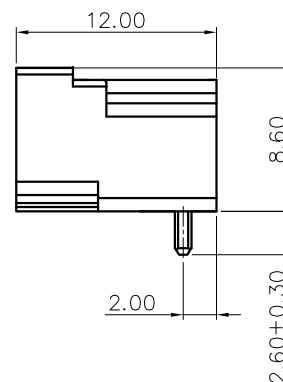
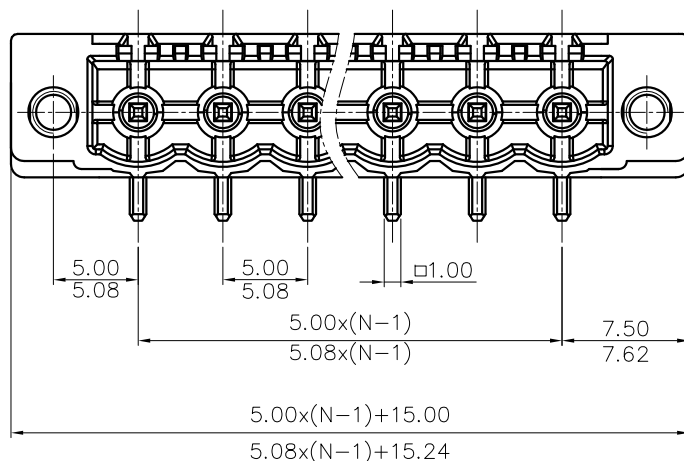
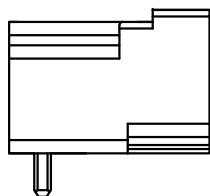
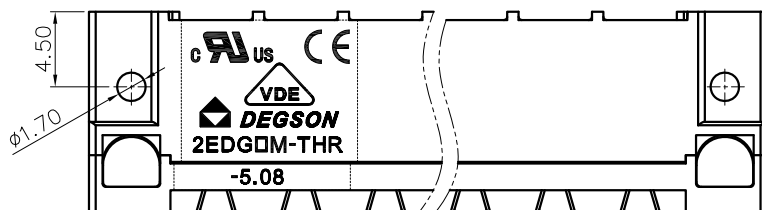

NOTES1:

UL Standard

1. Rated voltage/current : 300V / 15A
2. Withstanding voltage : AC1600V/1Min.

IEC Standard

1.

| | |
|--------------------------|-------|
| Pollution degree | 3 |
| Overtoltage category | III |
| Rate impulse voltage(KV) | 4.0KV |
| Rate voltage(V) | 320V |
| Rate current(A) | 20A |

NOTES2:

1. Dimension shall be interpreted per ASME Y14.5-2009
2. Pitch : 5.00/5.08mm, Poles : N=02~12P
3. Operating temperature: -40°C~+130°C
4. Undimensioned tolerances:

| Pitch range in mm | | Nominal dimension range in mm | | | | Tolerances | |
|-------------------|-------|-------------------------------|-------|-------|-------|------------|-------|
| To | Over | To | Over | To | Over | 0.1/10 | |
| 6 | 10 | 30 | 60 | 100 | 150 | < | ±2' |
| ±0.15 | ±0.20 | ±0.30 | ±0.30 | ±0.50 | ±0.70 | ±1.00 | ±1.30 |

5. RoHS Compliance

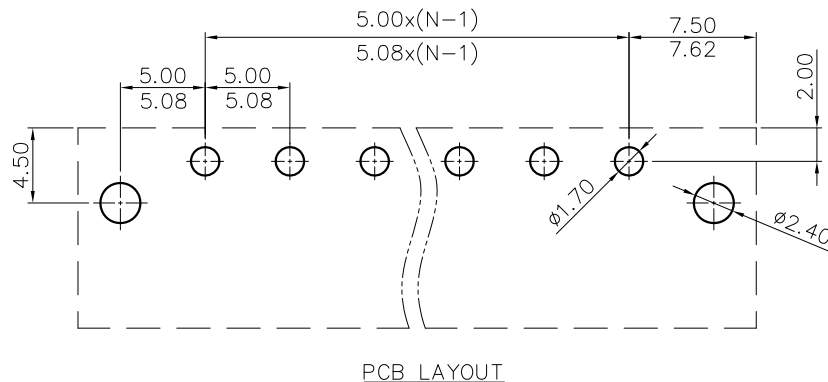

2EDGRM-THR - 5.00/5.08 - XXP - 1Y - 00A (H)
 (Series No.) (Pitch) (Poles) (Single Pitch) (Color): 1.(Grey) 3.(Black) 5.(Orange)
 (RoHS) 00A-(Standard)

| | | | | | | |
|------------------------|-------------------------|-----------|-------|----------------------|---|-----|
| DETACHED LISTS | PART NO.: | / | | | 宁波高松电子有限公司 NINGBO DEGSON ELECTRICAL CO., LTD | |
| | APPD: | / | NAME: | | 2EDGRM-THR-5.00/5.08-XXP-1Y-00A(H) | |
| | CHKD: | / | DRFT: | | / | |
| | TITLE: CUSTOMER DRAWING | | REV | DO | | |
| | DRAWING NO.: | | / | | SHEET | 1/1 |
| THIRD ANGLE PROJECTION | | MM (INCH) | | DO NOT SCALE DRAWING | SCALE 1:1 | |