

REVISION RECORD				
REV	ECN	DESCRIPTION	DRFT	DATE

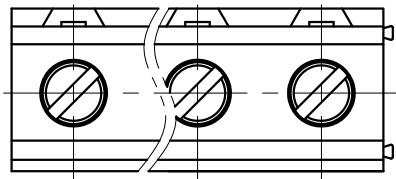

NOTES1:

UL Standard

- 1.Rated voltage/current : 300V / 20A
- 2.Torque value : M3 , 4.43Lb.in
- 3.Wire range : 30~12AWG

IEC Standard

- 1.Rated voltage/current : 450V / 18A
- 2.Torque value : M3 , 0.5N·m
- 3.Wire range : 1.0~2.5mm<sup>2</sup>

NOTES2:

- 1.Dimension shall be interpreted per ASME Y14.5-2009
- 2.Pitch : 7.62mm, Poles : N=02~16P
- 3.Stripping length : 6~7mm
- 4.Withstanding voltage : AC2500V/1Min
- 5.Operating temperature : -40°C~+105°C
- 6.Undimensioned tolerances:

Pitch range in mm		Nominal dimension range in mm					-	∩	□
TO	Over	TO	Over	TO	Over	TO	Over	TO	
6	10	30	60	100	150				
10	24	60	100	150		0.1/10			
±0.15	±0.20	±0.30	±0.50	±0.70	±1.00	±1.30	±2*		

7.RoHS Compliance

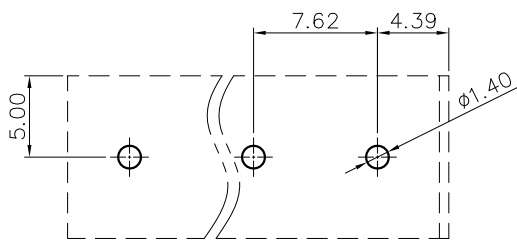
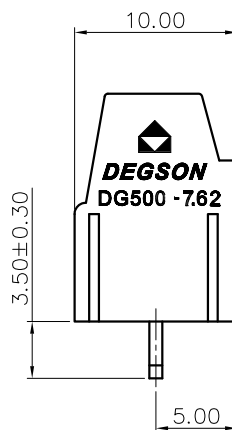
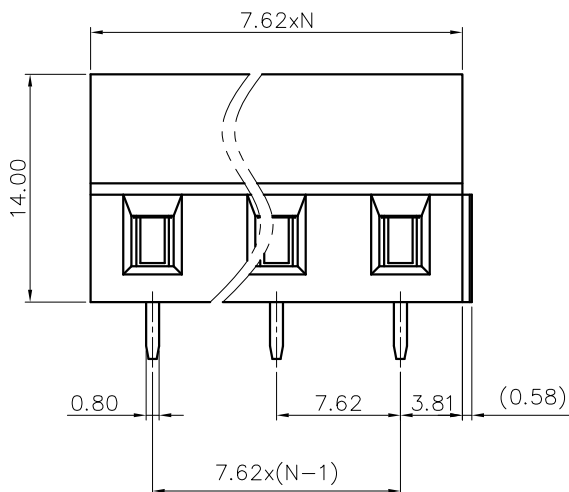
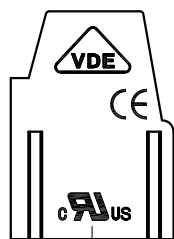
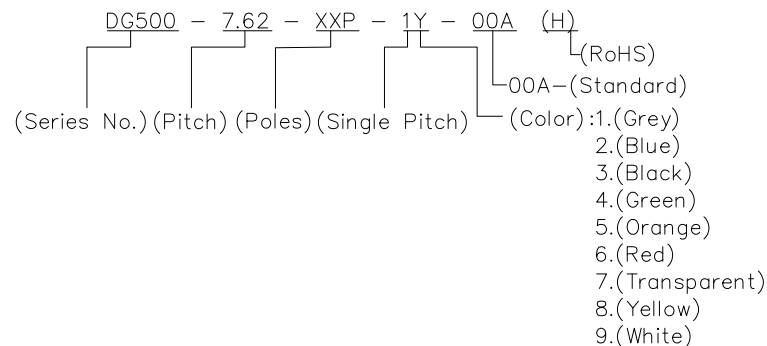

PCB LAYOUT

DETACHED LISTS	PART NO.:	宁波高松电子有限公司 NINGBO DEGSON ELECTRICAL CO., LTD			
	APPD:	NAME: DG500-7.62-XXP-1Y-00A(H)			
	CHKD:	TITLE: CUSTOMER DRAWING		REV	DO
	DRFT:	DRAWING NO.:		SHEET	1/1
THIRD ANGLE PROJECTION		MM (INCH)	DO NOT SCALE DRAWING	SCALE	1:1